

ChinaBalers

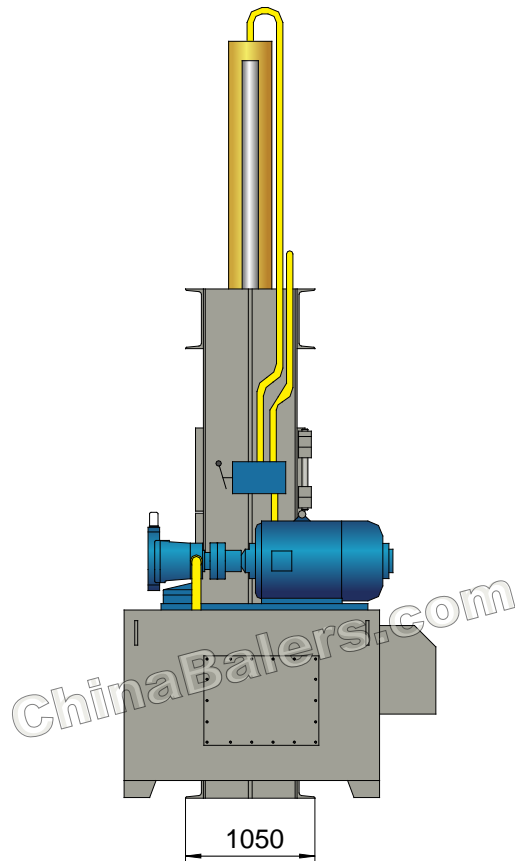

Y82-X Yarn & Waste Cotton Baler

YE82-15X

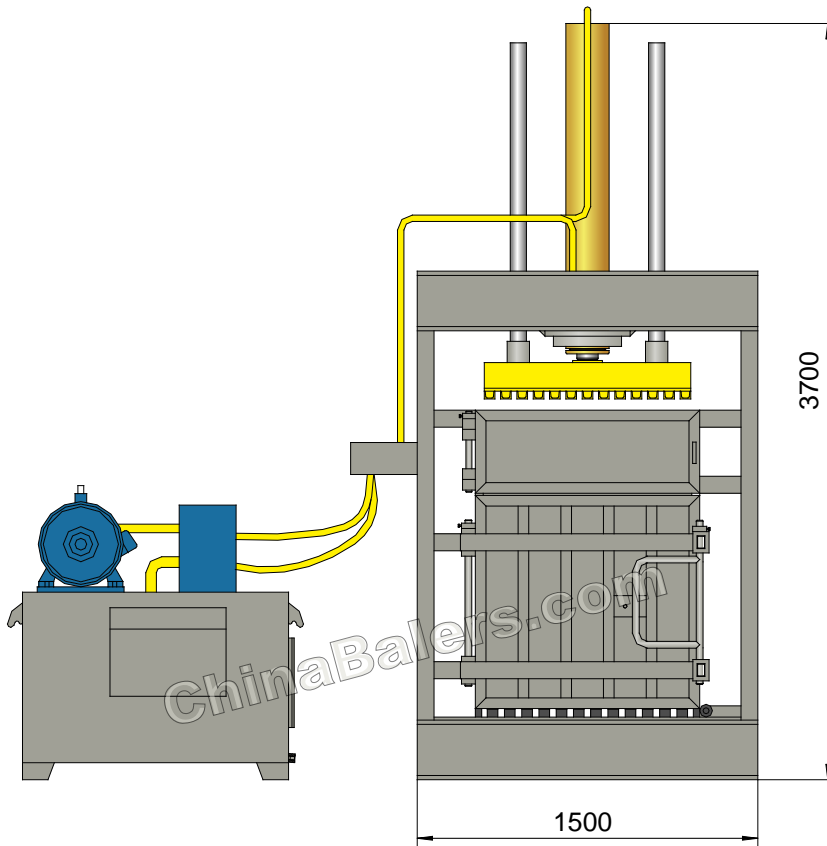
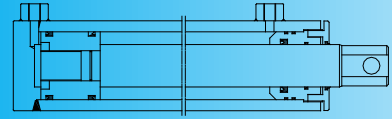

YE82-15X

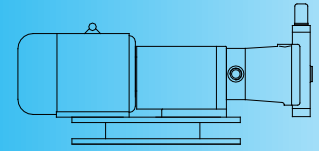

Yarn & Waste Cotton Baler

Model: YE82-15X

Power System (Motor)

Type:	Y132M-4
Rated Power:	7.5 kW
Rated Speed:	1440 rpm
Power Spec:	3PH, 50 / 60Hz

System Parameters

Main Pressure Cyl. Force:	15 Ton
Hydraulic System Pressure:	10 MPa

Hydraulic System (Pump)

Type:	PEED-43037/022/DWA
Rated Displacement:	48+26 ml/r
Max Operating Pressure:	14 MPa

Standard Configuration

NOK (JAPAN) Seal Packings for Cylinders.

Operation System

Manual Valve Operation

General Description

Main Machine Size (L×W×H):	1680×1050×3700 mm
Press Box Size (L×W×H):	870×620×1500 mm
Space Between Ram & Bottom:	Max. 1500 mm; Min. 300 mm
Bale Size (L×W):	870×620 mm
Bale Weight (Waste Cotton):	Approx. 80 kg
Production Rate (Waste Cotton):	400-550 kg/hr
Strapping:	Tempered Iron Wire, ϕ 2.8/3.2mm, Manual Strapping.
Bale Discharging:	Manual Discharging
Shipping Weight:	Approx. 2.2 tons
Loading (Standard Containers):	1/2×20'GP

Hydraulic Oil Brand

Oil Tank Volume:

320 ltr

ISO VG	China	U.S.		Britain	France
	GB11118.1	CALTEX CO.	MOBIL	SHELL	ELF CO.
HM 46	46 #	Rando HD46	D.T.E46	Tellus 46	Elfolna 46
HM 68	68 #	Rando HD68	D.T.E68	Tellus 68	Elfolna 68

Above information are indicative not engaging. Rights reserved for change if necessary.

Y82-25X

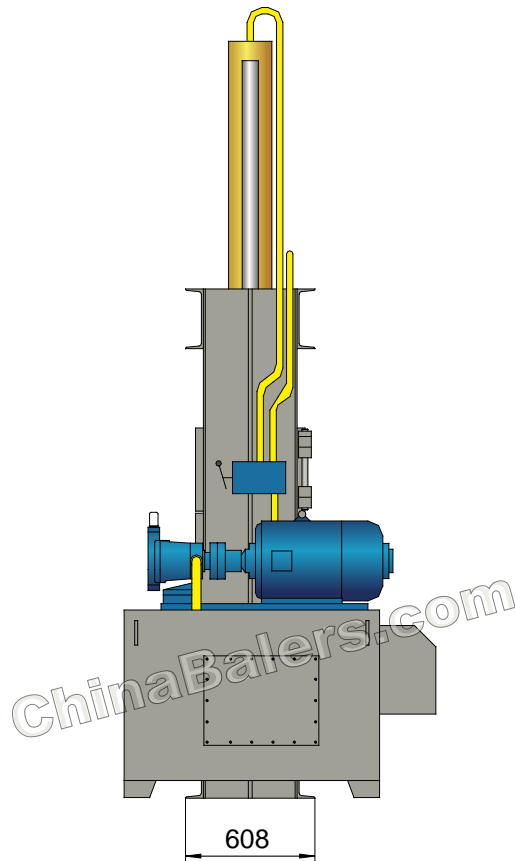
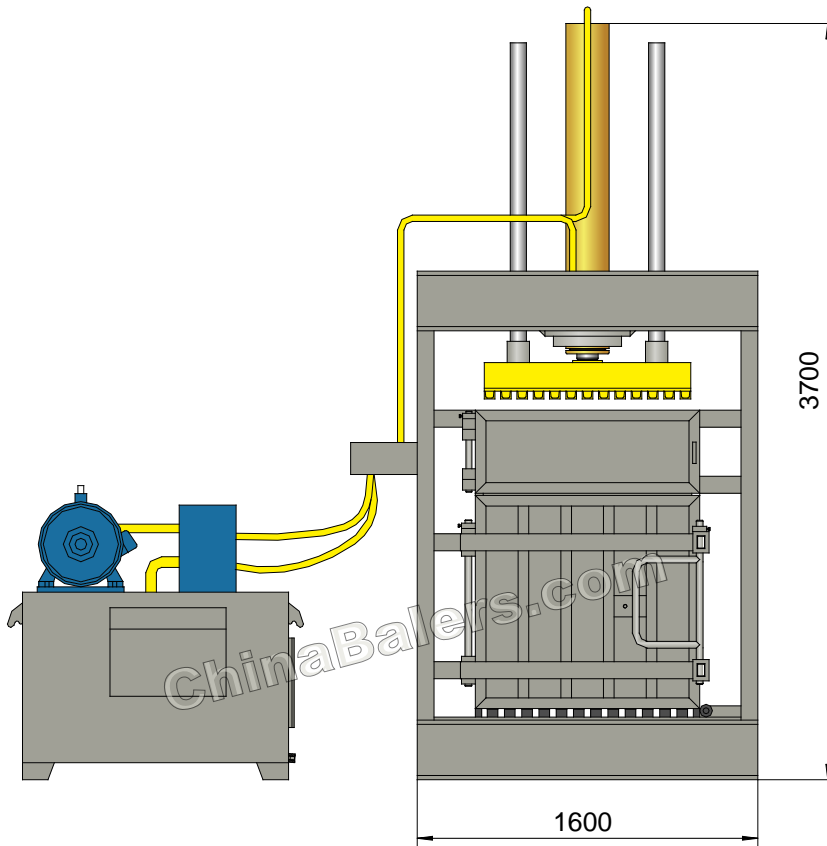
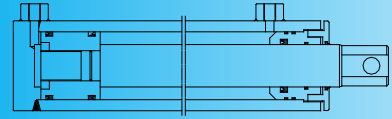

Y82-25X

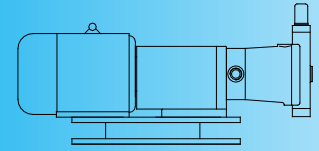

Yarn & Waste Cotton Baler

Model: Y82-25X

Power System (Motor)

Type:	Y180L-6
Rated Power:	15 kW
Rated Speed:	970 rpm
Power Spec:	3PH, 50 / 60Hz

System Parameters

Main Pressure Cyl. Force:	25 Ton
Hydraulic System Pressure:	12.5 MPa

Hydraulic System (Pump)

Type:	63YCY14-1B
Rated Displacement:	63 ml/r
Max Operating Pressure:	31.5 MPa

Standard Configuration

NOK (JAPAN) Seal Packings for Cylinders.

Operation System

Manual Valve Operation

General Description

Main Machine Size (L×W×H):	1850×700×3700 mm
Press Box Size (L×W×H):	980×430×1400 mm
Space Between Ram & Bottom:	Max. 1450 mm; Min. 250 mm
Bale Size (L×W):	980×430 mm
Bale Weight (Waste Cotton):	Approx. 70 kg
Production Rate (Waste Cotton):	350-450 kg/hr
Strapping:	Tempered Iron Wire, ϕ 2.8/3.2mm, Manual Strapping.
Bale Discharging:	Manual Discharging
Shipping Weight:	Approx. 2.3 tons
Loading (Standard Containers):	1/2×20'GP

Hydraulic Oil Brand

Oil Tank Volume:

320 ltr

ISO VG	China	U.S.		Britain	France
	GB11118.1	CALTEX CO.	MOBIL	SHELL	ELF CO.
HM 46	46 #	Rando HD46	D.T.E46	Tellus 46	Elfolna 46
HM 68	68 #	Rando HD68	D.T.E68	Tellus 68	Elfolna 68

Above information are indicative not engaging. Rights reserved for change if necessary.

YE82-63X

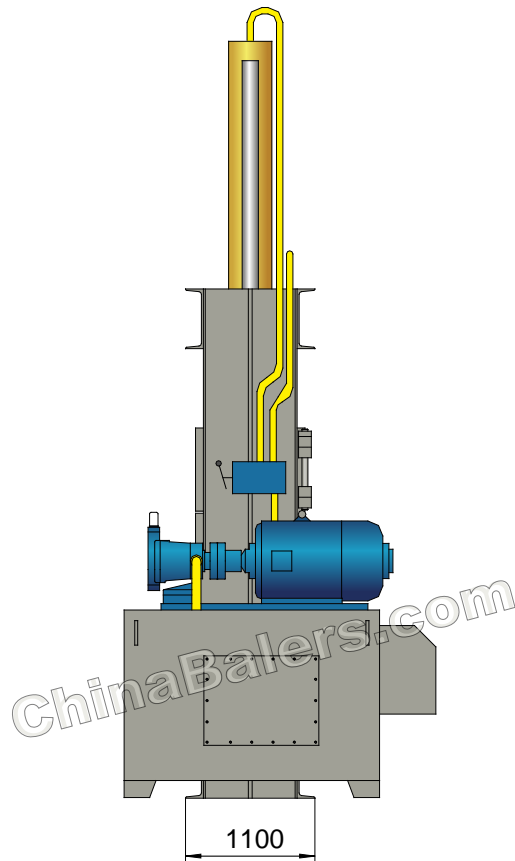
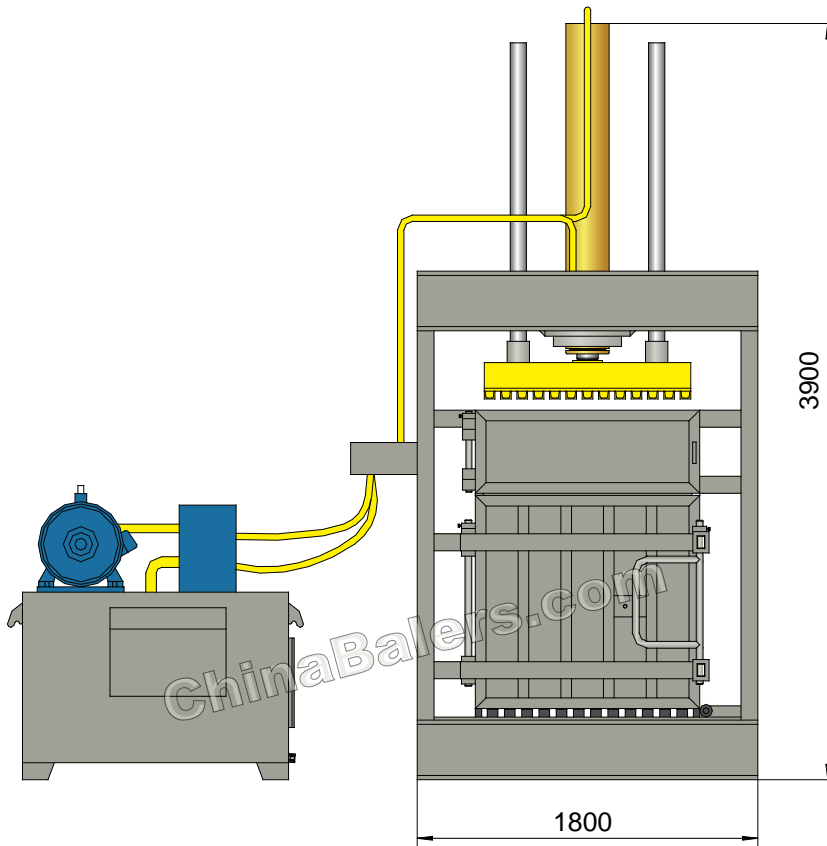
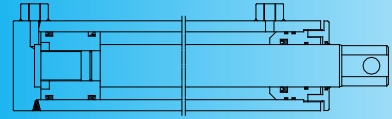

YE82-63X

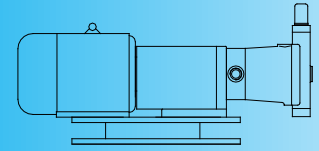

Yarn & Waste Cotton Baler

Model: YE82-63X

Power System (Motor)

Type:	Y180L-6
Rated Power:	15 kW
Rated Speed:	970 rpm
Power Spec:	3PH, 50 / 60Hz

System Parameters

Main Pressure Cyl. Force:	63 Ton
Hydraulic System Pressure:	20 MPa

Hydraulic System (Pump)

Type:	63YCY14-1B
Rated Displacement:	63 ml/r
Max Operating Pressure:	31.5 MPa

Standard Configuration

NOK (JAPAN) Seal Packings for Cylinders.

Operation System

Manual Valve Operation

General Description

Main Machine Size (L×W×H):	2050×1100×3900 mm
Press Box Size (L×W×H):	1100×760×1500 mm
Space Between Ram & Bottom:	Max. 1550 mm; Min. 350 mm
Bale Size (L×W):	1100×760 mm
Bale Weight (Waste Cotton):	Approx. 150 kg
Production Rate (Waste Cotton):	750-1000 kg/hr
Strapping:	Tempered Iron Wire, ϕ 2.8/3.2mm, Manual Strapping.
Bale Discharging:	Manual Discharging
Shipping Weight:	Approx. 3.6 tons
Loading (Standard Containers):	1/2×20'GP

Hydraulic Oil Brand

Oil Tank Volume:

320 ltr

ISO VG	China	U.S.		Britain	France
	GB11118.1	CALTEX CO.	MOBIL	SHELL	ELF CO.
HM 46	46 #	Rando HD46	D.T.E46	Tellus 46	Elfolna 46
HM 68	68 #	Rando HD68	D.T.E68	Tellus 68	Elfolna 68

Above information are indicative not engaging. Rights reserved for change if necessary.



**Soochow Baling Machinery Ltd.
Jiangsu Huahong Technology Stock Co., Ltd.**

Factory: Zhouzhuang, Jiangyin, Jiangsu

Office: Rm 1202, SIPCTD Bldg, No. 381 Suzhou Avenue East,
Suzhou Industrial Park, Suzhou, Jiangsu 215028 China

Tel: +86 512 6255 1141 **Fax:** +86 512 6255 1142

Email: info@chinabalers.com; chinabalers@foxmail.com

Website: www.chinabalers.com; www.chinabalers.net