

**ChinaBalers**

# Y82-B Cloth, Bags & Sacks Baler

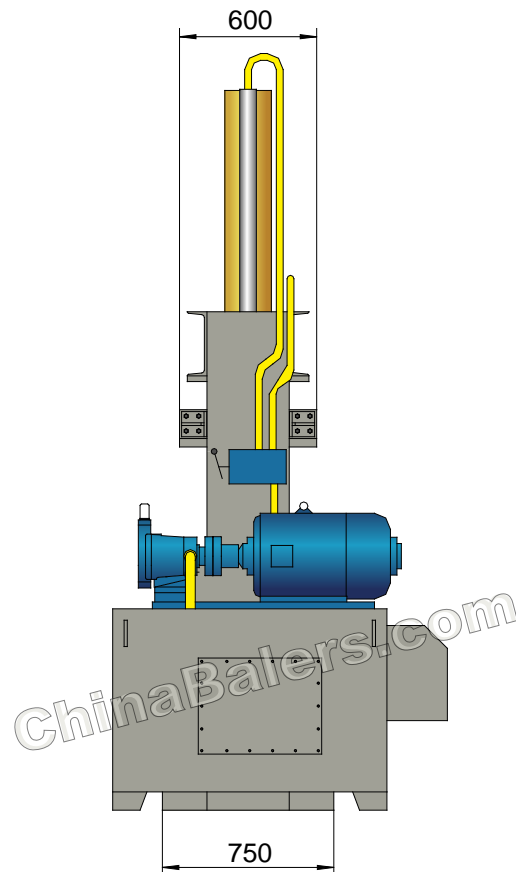

# Y82-25B

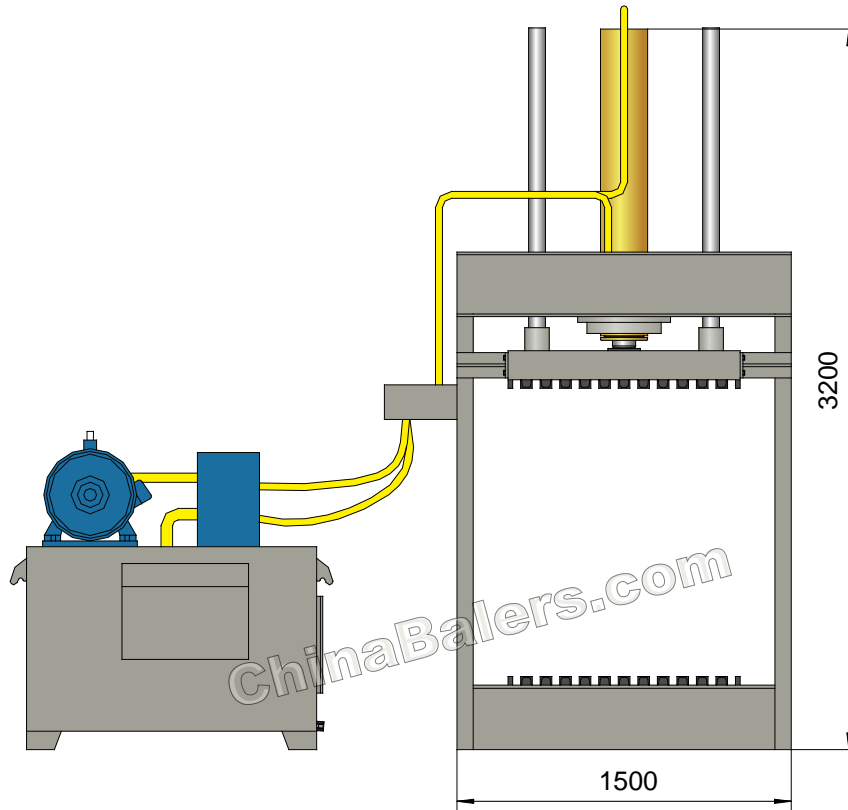
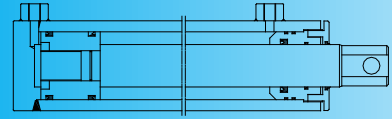

# Y82-25B

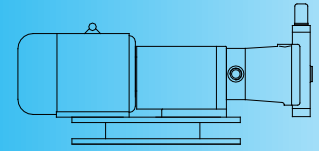

Cloth / Woven Bags / Sacks Baler

Model: Y82-25B

## Power System (Motor)

Type: Y160L-6  
Rated Power: 11 kW  
Rated Speed: 970 rpm  
Power Spec: 3PH, 50 / 60Hz

## System Parameters

Main Pressure Cyl. Force: 25 Ton  
Hydraulic System Pressure: 12.5 MPa

## Hydraulic System (Pump)

Type: CBA1050  
Rated Displacement: 50 ml/r  
Max Operating Pressure: 21 MPa

## Standard Configuration

NOK (JAPAN) Seal Packings for Cylinders.

## Operation System

Manual Valve Operation

## General Description

Main Machine Size (L×W×H): 1500×750×3200 mm  
Working Table Size (L×W): 1300×750 mm  
Pressure Ram Size (L×W): 1000×600 mm  
Space Between Ram & Table: Max. 1250 mm; Min. 250 mm  
Strapping: Tempered Iron Wire,  $\phi$ 2.8/3.2mm, Manual Strapping.  
Bale Discharging: Manual Discharging  
Shipping Weight: Approx. 1.8 tons  
Loading (Standard Containers): 1/3×20'GP

## Hydraulic Oil Brand

Oil Tank Volume: 320 ltr

ISO VG	China	U.S.		Britain	France
	GB11118.1	CALTEX CO.	MOBIL	SHELL	ELF CO.
HM 46	46 #	Rando HD46	D.T.E46	Tellus 46	Elfolna 46
HM 68	68 #	Rando HD68	D.T.E68	Tellus 68	Elfolna 68

Above information are indicative not engaging. Rights reserved for change if necessary.

# YE82-63B

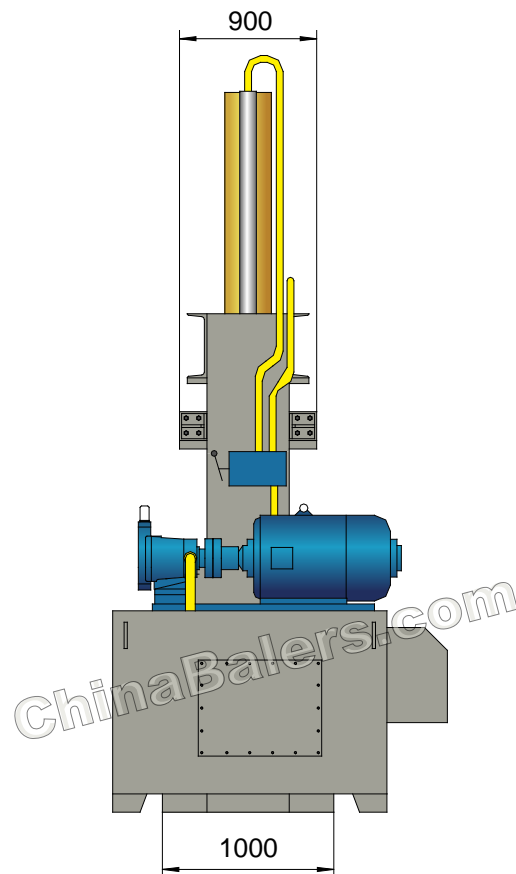
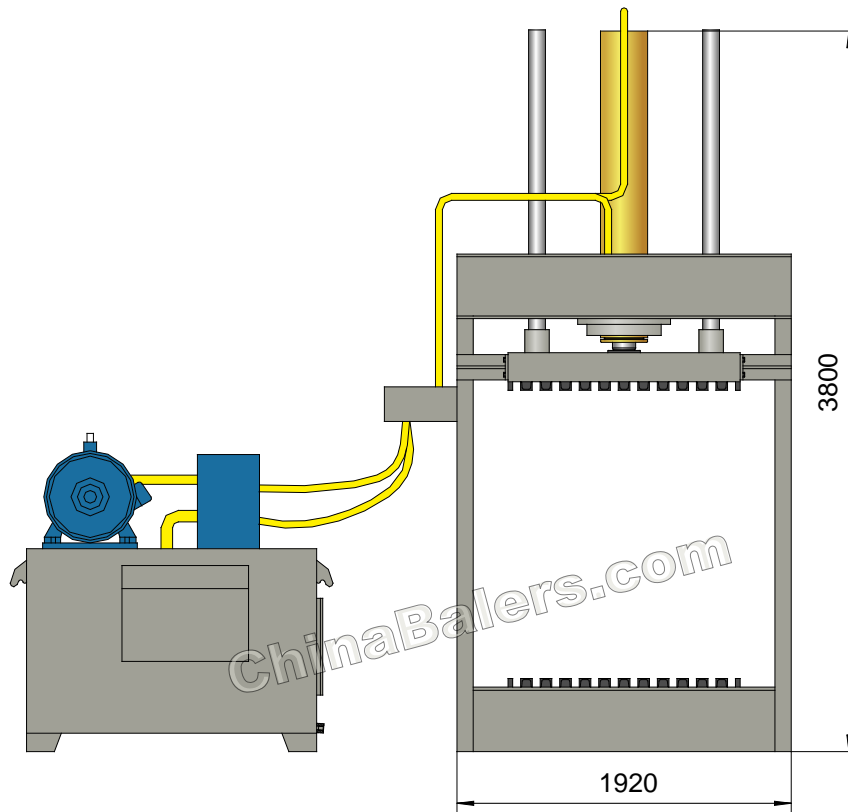
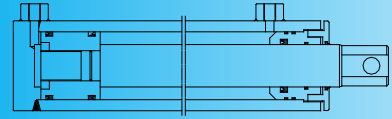

# YE82-63B

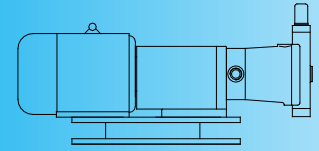

Cloth / Woven Bags / Sacks Baler

Model: YE82-63B

## Power System (Motor)

Type: Y180L-6  
Rated Power: 15 kW  
Rated Speed: 970 rpm  
Power Spec: 3PH, 50 / 60Hz

## System Parameters

Main Pressure Cyl. Force: 63 Ton  
Hydraulic System Pressure: 20 MPa

## Hydraulic System (Pump)

Type: 63YCY14-1B  
Rated Displacement: 63 ml/r  
Max Operating Pressure: 31.5 MPa

## Standard Configuration

NOK (JAPAN) Seal Packings for Cylinders.

## Operation System

Manual Valve Operation

## General Description

Main Machine Size (L×W×H): 1920×1000×3800 mm  
Working Table Size (L×W): 1600×1000 mm  
Pressure Ram Size (L×W): 1350×900 mm  
Space Between Ram & Table: Max. 1400 mm; Min. 200 mm  
Strapping: Tempered Iron Wire,  $\phi$ 2.8/3.2mm, Manual Strapping.  
Bale Discharging: Manual Discharging  
Shipping Weight: Approx. 3.7 tons  
Loading (Standard Containers): 1/2×20'GP

## Hydraulic Oil Brand

Oil Tank Volume: 320 ltr

ISO VG	China	U.S.		Britain	France
	GB11118.1	CALTEX CO.	MOBIL	SHELL	ELF CO.
HM 46	46 #	Rando HD46	D.T.E46	Tellus 46	Elfolna 46
HM 68	68 #	Rando HD68	D.T.E68	Tellus 68	Elfolna 68

Above information are indicative not engaging. Rights reserved for change if necessary.

# Y82-120B

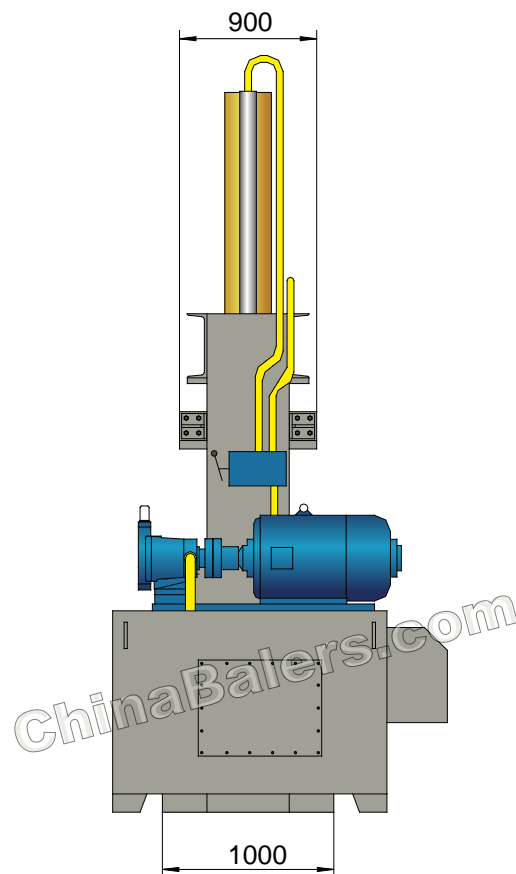
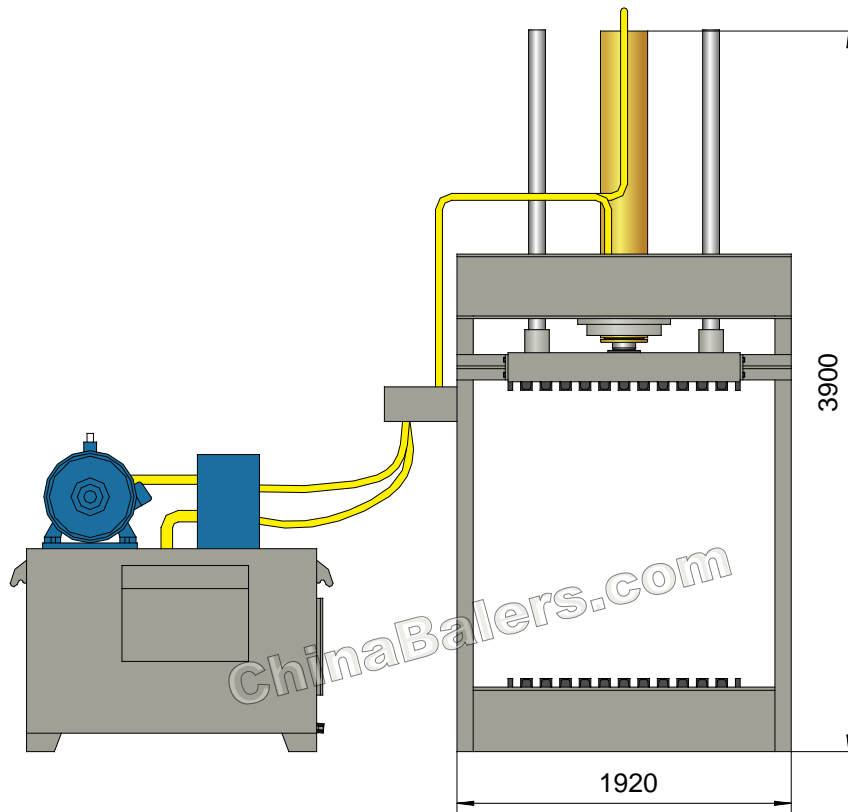
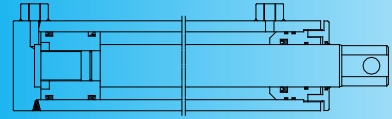

# Y82-120B

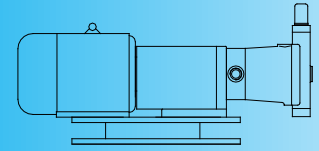

Cloth / Woven Bags / Sacks Baler

Model: Y82-120B

## Power System (Motor)

Type: Y180M-4  
Rated Power: 18.5 kW  
Rated Speed: 970 rpm  
Power Spec: 3PH, 50 / 60Hz

## System Parameters

Main Pressure Cyl. Force: 120 Ton  
Hydraulic System Pressure: 25 MPa

## Hydraulic System (Pump)

Type: 80YCY14-1B  
Rated Displacement: 80 ml/r  
Max Operating Pressure: 31.5 MPa

## Standard Configuration

NOK (JAPAN) Seal Packings for Cylinders.

## Operation System

Manual Valve Operation

## General Description

Main Machine Size (L×W×H): 1920×1000×3900 mm  
Working Table Size (L×W): 1600×1000 mm  
Pressure Ram Size (L×W): 1350×900 mm  
Space Between Ram & Table: Max. 1500 mm; Min. 300 mm  
Strapping: Tempered Iron Wire,  $\phi$ 2.8/3.2mm, Manual Strapping.  
Bale Discharging: Manual Discharging  
Shipping Weight: Approx. 5.8 tons  
Loading (Standard Containers): 1/2×20'GP

## Hydraulic Oil Brand

Oil Tank Volume: 480 ltr

ISO VG	China	U.S.		Britain	France
	GB11118.1	CALTEX CO.	MOBIL	SHELL	ELF CO.
HM 46	46 #	Rando HD46	D.T.E46	Tellus 46	Elfolna 46
HM 68	68 #	Rando HD68	D.T.E68	Tellus 68	Elfolna 68

Above information are indicative not engaging. Rights reserved for change if necessary.



**Soochow Baling Machinery Ltd.**

**Jiangsu Huahong Technology Stock Co., Ltd.**

**Factory:** Zhouzhuang, Jiangyin, Jiangsu

**Office:** Rm 1202, SIPCTD Bldg, No. 381 Suzhou Avenue East,  
Suzhou Industrial Park, Suzhou, Jiangsu 215028 China

**Tel:** +86 512 6255 1141 **Fax:** +86 512 6255 1142

**Email:** [info@chinabalers.com](mailto:info@chinabalers.com); [chinabalers@foxmail.com](mailto:chinabalers@foxmail.com)

**Website:** [www.chinabalers.com](http://www.chinabalers.com); [www.chinabalers.net](http://www.chinabalers.net)