

ChinaBalers

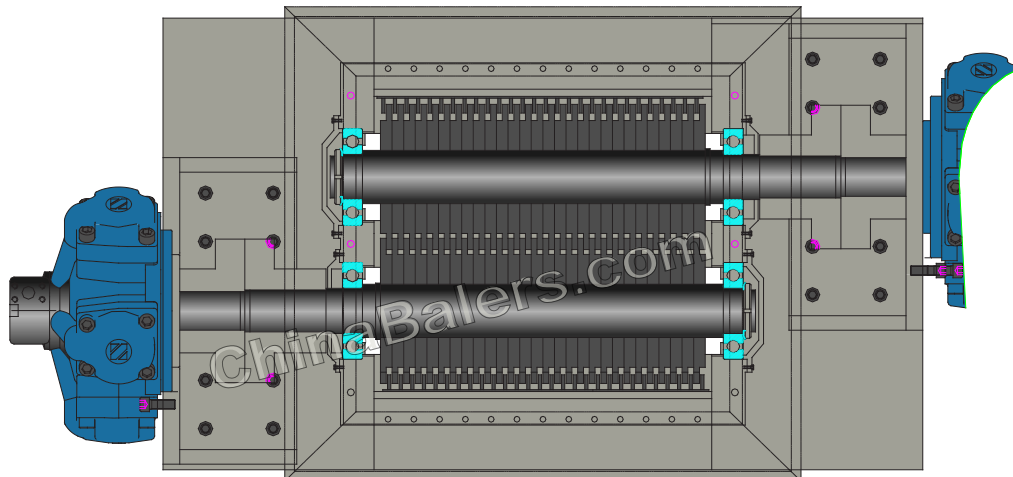

PS Turnings Crusher

PS-45100

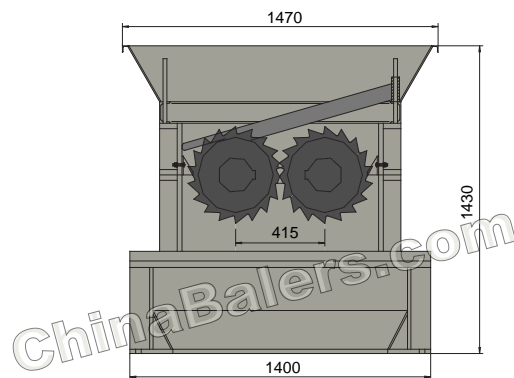
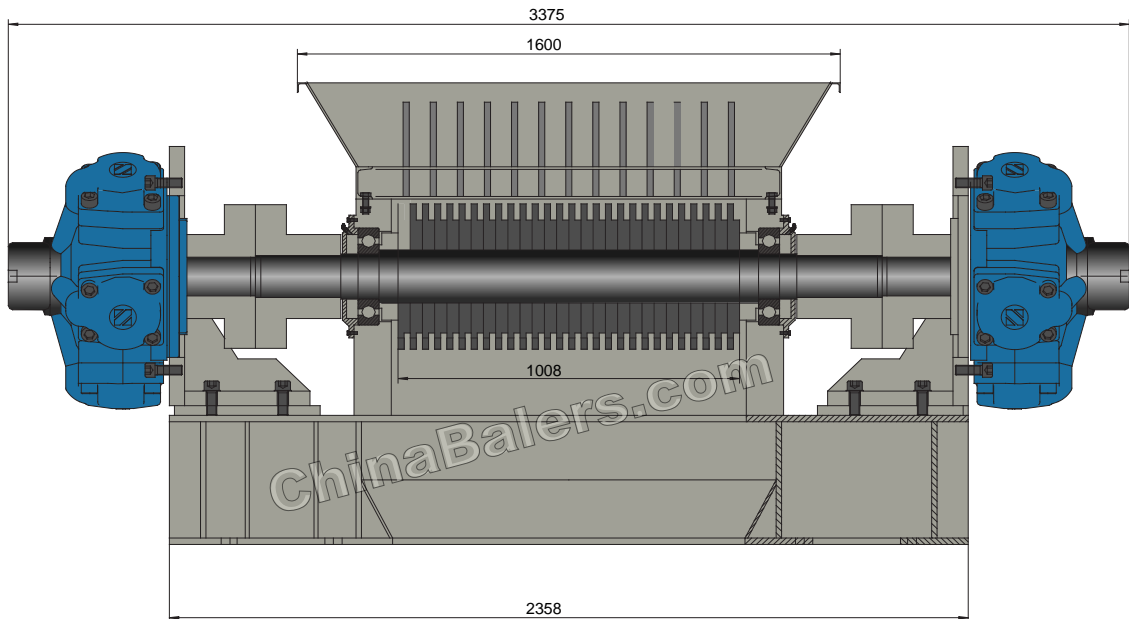
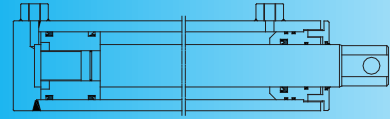

PS-45100

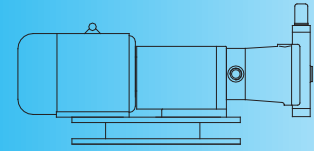

Turnings Chipper / Shredder

Model: PS-45100

Power System (Motor, 2 sets)

Motor #1: Y280S-4/B35
 Rated Power: 75 kW
 Rated Speed: 1480 rpm
 Power Spec: 3PH, 50 / 60Hz

Motor #2: Y200L-4/B35
 Rated Power: 30 kW
 Rated Speed: 1480 rpm
 Power Spec: 3PH, 50 / 60Hz

Hydraulic Pump, 2 sets

Pump #1: HY160S-RP
 Rated Displacement: 160 ml/r
 Max Operating Pressure: 31.5 MPa

Pump #2: HY80S-RP
 Rated Displacement: 80 ml/r
 Max Operating Pressure: 31.5 MPa

Hydraulic Motor, 2 sets

Type: JMDG100-8000B
 Rated Displacement: 7963 ml/r
 Rotation Range: 0.5~125 rpm
 Rated Torque: 28744 N·m
 Max. Operating Pressure: 25 MPa

System Parameters

Hydraulic System Pressure: 16 MPa

Operation System

PLC Operation

Standard Configuration

Oil Cooler; Blade Material Cr12MoV

Optional Configuration

Oil Heater; Magnetic Oil Filter

General Description

Main Machine Size (L×W×H): 3375×1470×1430 mm
 Feed Opening (L×W): 1600×1470 mm
 Main Shaft: φ450×1000 mm
 Main Shaft Rotation Speed: 15-20 rpm
 Finished Product (Steel Turnings): 25-50 mm
 Production Rate (Steel Turnings): 2-3 tons/hr
 Shipping Weight: Approx. 7 tons
 Loading (Standard Containers): 1×20'GP

Hydraulic Oil Brand

Oil Tank Volume:

2400 ltr

ISO VG	China	U.S.	Britain	France
	GB11118.1	CALTEX CO.	MOBIL	SHELL
HM 46	46 #	Rando HD46	D.T.E46	Tellus 46
HM 68	68 #	Rando HD68	D.T.E68	Tellus 68
				ELF CO.
				Elfolna 46
				Elfolna 68

Above information are indicative not engaging. Rights reserved for change if necessary.

Soochow Baling Machinery Ltd.
Jiangsu Huahong Technology Stock Co., Ltd.

Factory: Zhouzhuang, Jiangyin, Jiangsu

Office: Rm 1202, SIPCTD Bldg, No. 381 Suzhou Avenue East,
Suzhou Industrial Park, Suzhou, Jiangsu 215028 China

Tel: +86 512 6255 1141 **Fax:** +86 512 6255 1142

Email: info@chinabalers.com; chinabalers@foxmail.com

Website: www.chinabalers.com; www.chinabalers.net